

**RY RYE LA**

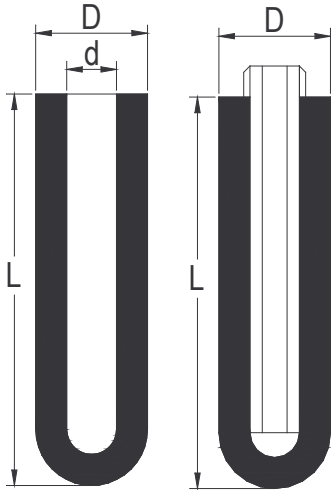

L mm	D mm	d mm
Min. 300	40.50 55,60	20.25 30
Max. 1500		

Pyrometer tubes

RYE:  
With steel tube and tread 3/8,  
1/2, 3/4"

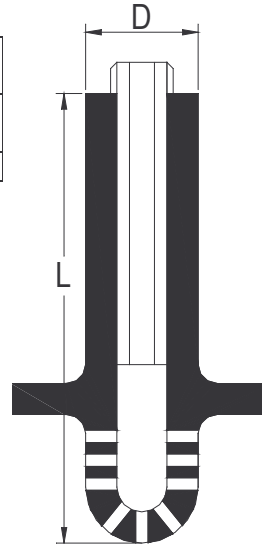

N° LA	L mm	D mm	Tread
4	750	60	1/2"
6	1000	60	1/2"
5	1300	60	1/2"
8	1500	60	1/2"

Degassing tube

**SC**

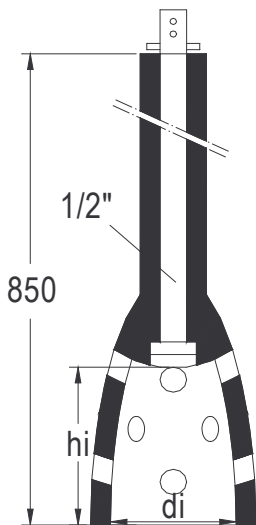

L mm	D mm	d mm
1	90	65
2	120	95
3	160	95
4	200	120

Plungers in clay-graphite

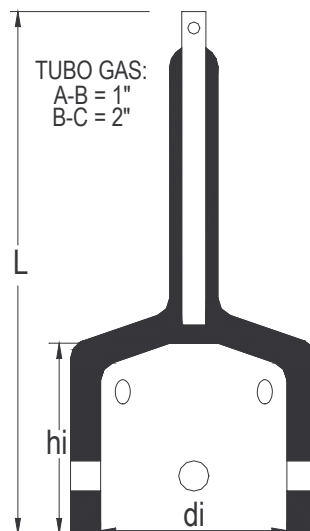

N°	H mm	D mm	d mm	L mm
G A	4 - 7	210	170	740
G B	7 - 10	240	200	780
G D	15 - 22	320	260	960
G F	34 - 47	410	330	1060

Plungers in high refractory material for treatment of nodular iron

Special dimension for the handle upon request

**SK**

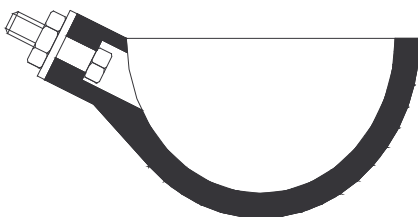

N°	Cap. l	Thread
SK 1	0.13	M 10
SK 2	0.33	M 16
SK 3	0.50	M 16
SK 4	0.60	M 16
SK 5	0.75	M 16

N°	Cap. l	Threa d
SK 6	1.50	M 16
SK 7	1.20	M 16
SK 8	2.2	M 16
SK9	3.2	M 16

Ladle bowls